

PNS Single Stage Dimensions

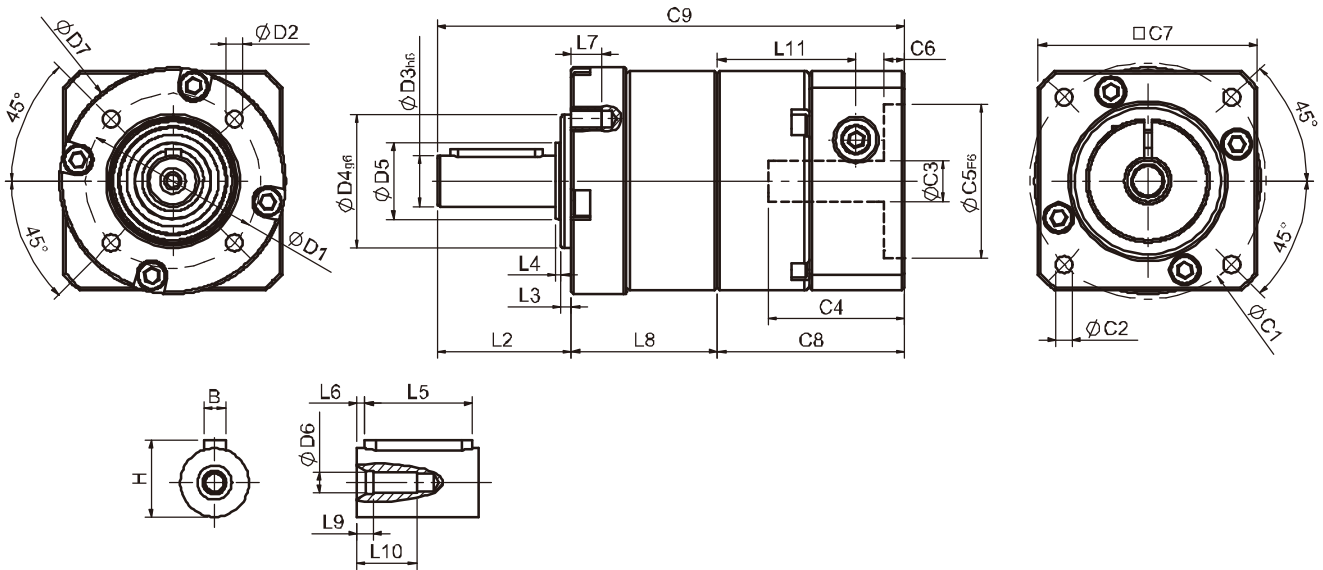

Specifications

Unit:mm

Dimensions	PNS40	PNS60	PNS80	PNS120	PNS160
D1	34	52	70	100	145
D2	M4x0.7P	M5x0.8P	M6x1.0P	M10x1.5P	M12x1.75P
D3 _{H6}	10	14	20	25	40
D4 _{H6}	26	40	60	80	130
D5	15	20	35	40	50
D6	M3x0.5P	M5x0.8P	M6x1.0P	M10x1.5P	M16x2.0P
D7	44	60	90	116	160
L2	26	35	40	55	87
L3	2	3	3	4	5
L4	1	1	1	1	2
L5	18	25	28	40	65
L6	2.5	2.5	4	5	8
L7	6	8	10	15	20
L8	28.4	34.4	42.2	68.8	81
L9	3	4	4.5	6	6
L10	9	16.5	16.5	26	38
L11	26.9	31.6	37.3	51.8	63
C1 ²	46	70	90	145	130
C2 ²	M4x0.7P	M5x0.8P	M6x1.0P	M8x1.25P	M8x1.25P
C3 ²	≤8/≤11	≤14/≤19	≤19/≤24/≤28	≤24/≤32/≤38	≤35/≤38
C4 ²	26.5	33.5	41	51.5	66.5
C5 ² _{F6}	30	50	70	110	110
C6 ²	4	4	6	6	5.5
C7 ²	42.6	60	90	130	140
C8 ²	36.4	42.1	51.5	68	80
C9 ²	90.8	111.5	133.7	191.8	248
B	3	5	6	8	12
H	11.2	16	22.5	28	43

* C1~C9 are motor specific dimensions (metric std shown). Size may vary according to motor flange.

* Specification subject to change without notice.

PNS Double Stage Dimensions

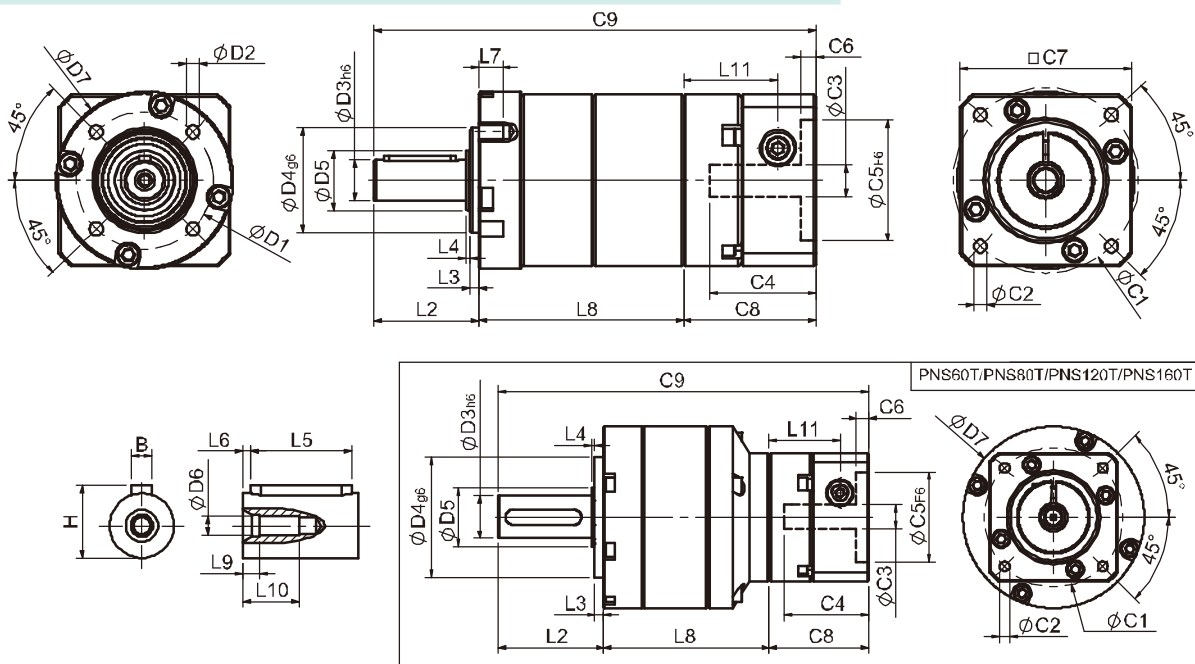

Specifications

Unit:mm

Dimensions	PNS40	PNS60	PNS60T	PNS80	PNS80T	PNS120T	PNS160	PNS160T
D1	34	52		70		100	145	
D2	M4x0.7P	M5x0.8P		M6x1.0P		M10x1.5P	M12x1.75P	
D3 _{h6}	10	14		20		25	40	
D4 _{g6}	26	40		60		80	130	
D5	15	20		35		40	50	
D6	M3x0.5P	M5x0.8P		M6x1.0P		M10x1.5P	M16x2.0P	
D7	44	60		90		116	160	
L2	26	35		40		55	87	
L3	2	3		3		4	5	
L4	1	1		1		1	2	
L5	18	25		28		40	65	
L6	2.5	2.5		4		5	8	
L7	6	8		10		15	20	
L8	50.85	61.4	54.7	76	71.5	106.9	142	129
L9	3	4		4.5		6	6	
L10	9	16.5		16.5		26	38	
L11	23.4	31	23.4	37.3	31	37.3	63	42
C1 ²	46	70	46	90	70	90	130	115
C2 ²	M4x0.7P	M5x0.8P	M4x0.7P	M6x1.0P	M5x0.8P	M6x1.0P	M8x1.25P	M8x1.25P
C3 ²	≤8/≤11	≤14/≤19	≤8/≤11	≤19/≤24/≤28	≤14/≤19	≤19/≤24/≤28	≤35/≤38	≤24/≤28
C4 ²	26.5	33.5	26.5	41	33.5	41	66.5	53.5
C5 ² _{h6}	30	50	30	70	50	70	110	95
C6 ²	4	4	4	6	4	6	5.5	5.5
C7 ²	42.6	60	42.6	90	60	90	140	120
C8 ²	32.9	41.5	32.9	51.5	41.5	51.5	80	58
C9 ²	109.75	137.9	122.6	167.5	153	213.4	309	274
B	3	5		6		8	12	
H	11.2	16		22.5		28	43	

* C1~C9 are motor specific dimensions (metric std shown). Size may vary according to motor flange.

* Specification subject to change without notice.

PNS Triple Stage Dimensions-1

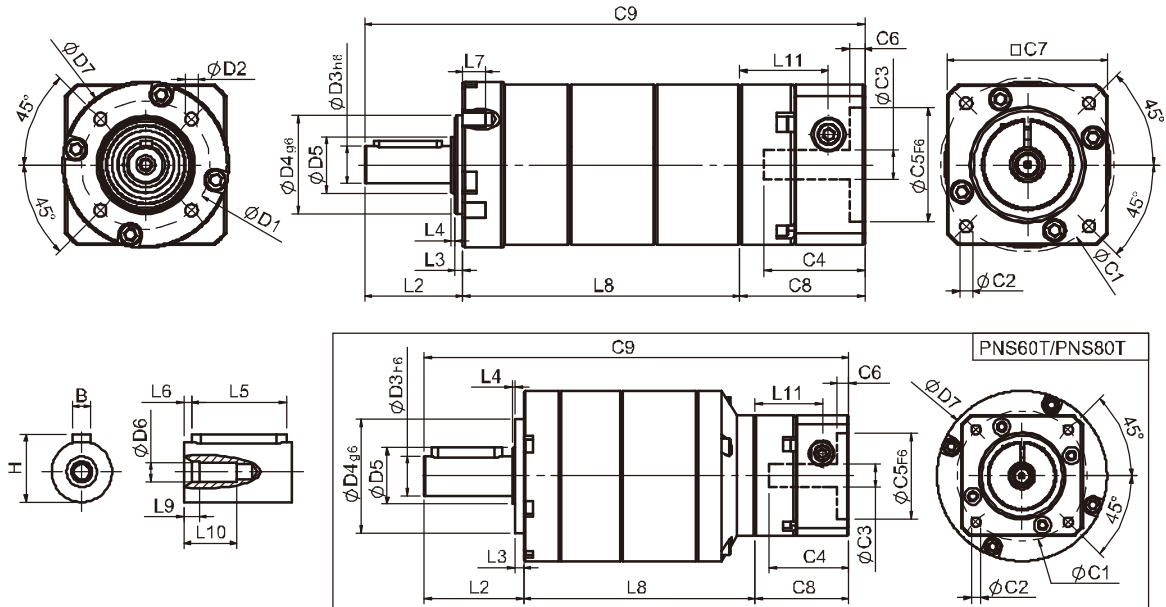

Specifications

Unit:mm

Dimensions	PNS40	PNS60T	PNS80T
D1	34	52	70
D2	M4x0.7P	M5x0.8P	M6x1.0P
D3 _{h5}	10	14	20
D4 _{g6}	26	40	60
D5	15	20	35
D6	M3x0.5P	M5x0.8P	M6x1.0P
D7	44	60	90
L2	26	35	40
L3	2	3	3
L4	1	1	1
L5	18	25	28
L6	2.5	2.5	4
L7	6	8	10
L8	73.3	81.7	105.3
L9	3	4	4.5
L10	9	16.5	16.5
L11	23.4	23.4	31
C1 ²	46	46	70
C2 ²	M4x0.7P	M4x0.7P	M5x0.8P
C3 ²	<8/<11	<8/<11	<14/<19
C4 ²	26.5	26.5	33.5
C5 ² _{F6}	30	30	50
C6 ²	4	4	4
C7 ²	42.6	42.6	60
C8 ²	32.9	32.9	41.5
C9 ²	132.2	149.6	186.8
B	3	5	6
H	11.2	16	22.5

- ★ C1~C9 are motor specific dimensions (metric std shown). Size may vary according to motor flange.
- ★ Specification subject to change without notice.

PNS Triple Stage Dimensions-2

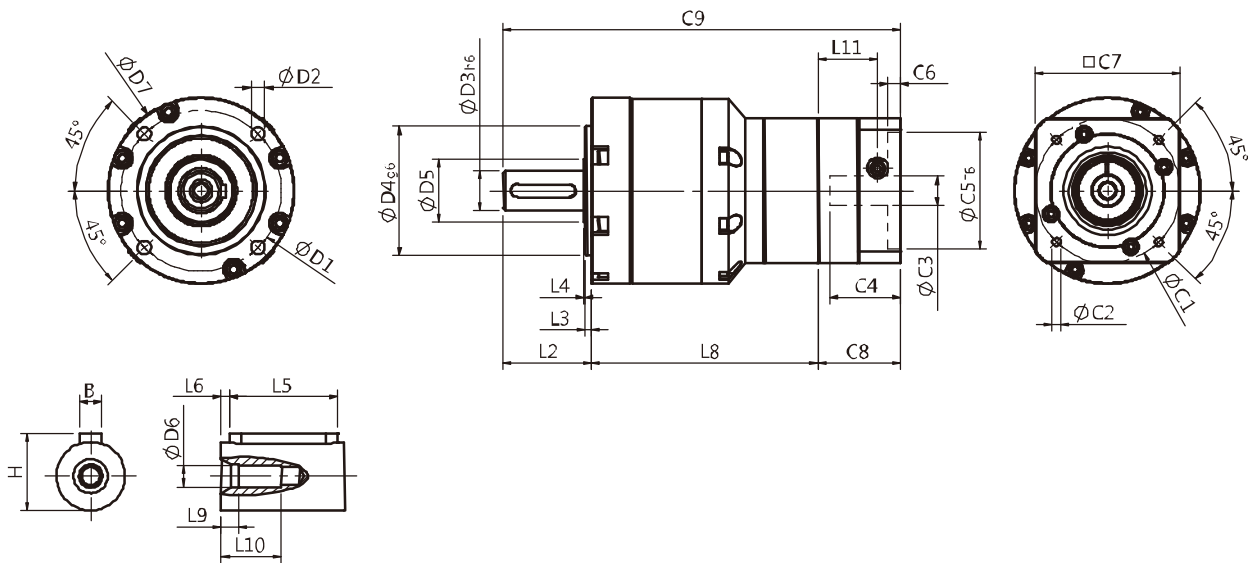

Specifications

Unit:mm

Dimensions	PNS120T	PNS160T
D1	100	145
D2	M10x1.5P	M12x1.75P
D3 _{h6}	25	40
D4 _{g6}	80	130
D5	40	50
D6	M10x1.5P	M16x2.0P
D7	116	160
L2	55	87
L3	4	5
L4	1	2
L5	40	65
L6	5	8
L7	15	20
L8	140.7	177
L9	6	6
L10	26	38
L11	37.3	42
C1 ²	90	115
C2 ²	M6x1.0P	M8x1.25P
C3 ²	≤19/≤24/≤28	24/≤28
C4 ²	41	53.5
C5 ² _{F6}	70	95
C6 ²	6	5.5
C7 ²	90	120
C8 ²	51.5	58
C9 ²	247.2	322
B	8	12
H	28	43

* C1~C9 are motor specific dimensions (metric std shown). Size may vary according to motor flange.
 * Specification subject to change without notice.

PNS Specifications Table

Specifications		Stage	Ratio	PNS-40	PNS-60	PNS-80	PNS-120	PNS-160		
Nominal Output Torque T_{2N}	N · m	1	3	9	28	85	200	420		
			4	10	32	80	215	490		
			5	11	35	95	215	473		
			7	10	28	85	200	400		
			9	8	23	75	195	320		
		10	8	21	65	180	320			
		Stage	Ratio	PNS-40	PNS-60/ PNS-60T	PNS-80/ PNS-80T	PNS-120T	PNS-160/ PNS-160T		
		2	15	11	35/24	95/68	168	420		
			20	11	35/31	95/95	215	490		
			25	11	35/30	95/95	215	473		
			35	11	35/28	95/95	215	473		
			45	11	35/27	95/92	215	473		
			50	(Ratio 49) : 10	35/27	95/82	205	473		
			70	(Ratio 63) : 10	28/28	85/85	200	400		
			90	(Ratio 81) : 8	23/23	75/75	195	320		
		100	8	21/21	65/65	180	320			
		Stage	Ratio	PNS-40	PNS-60T	PNS-80T	PNS-120T	PNS-160T		
		3	125	11	35	95	215	473		
			175	11	35	95	215	473		
			225	11	35	95	215	473		
			245	11	35	95	215	(Ratio 250) : 473		
			315	11	35	95	215	(Ratio 350) : 473		
			405	11	35	95	215	(Ratio 400) : 473		
			567	10	28	85	200	(Ratio 500) : 473		
			729	8	23	75	195	(Ratio 700) : 400		
		1000	8	21	65	180	320			
		Emergency Stop Torque T_{2NO}	N · m	2.5 times of Nominal Output Torque (* Max. Output Torque T_{2B} = 60% of Emergency Stop Torque)						
		Nominal Input Speed n_{1N}	rpm	1,2,3	3-1000	4000	4000	3000	2500	2500
Max. Input Speed n_{1max}	rpm	1,2,3	3-1000	6000	6000	6000	5000	4000		
Standard Backlash P2	arcmin	1	3-10	≤ 9	≤ 8	≤ 7	≤ 6	≤ 5		
		2	15-100	≤ 12	≤ 10	≤ 9	≤ 8	≤ 7		
		3	125~1000	≤ 15	≤ 12	≤ 12	≤ 12	≤ 10		
Torsional Rigidity	N · m / arcmin	1,2,3	3-1000	1.2	3.5	8.5	17	30		
Max. Radial Load F_{rB}^1	N	1,2,3	3-1000	580	890	2050	4370	6720		
Max. Axial Load F_{2aB}^1	N	1,2,3	3-1000	410	430	1100	2630	4200		
Operating Temp.	°C	1,2,3	3-1000	-10°C ~ +90°C						
Service Life	hr	1,2,3	3-1000	20,000 (10,000 Continuous operation)						
Efficiency	%	1	3-10	≥ 95%						
		2	15-100	≥ 90%						
		3	125~1000	≥ 85%						
Weight	kg	1	3-10	0.5	1.1	2.8	6.3	15.6		
		2	15-100	0.7	1.5/1.3	4.2/3.1	7.9	20.7/17.2		
		3	125~1000	0.8	1.7	4.5	9.3	9.3/19.2		
Mounting Position	-	1,2,3	3-1000	Any direction						
Noise Level ²	dBA/1m	1,2,3	3-1000	60	63	66	67	68		
Protection Class	-	1,2,3	3-1000	IP65						
Lubrication	-	1,2,3	3-1000	Synthetic Lubricant						
Inertia (J1)										
Stage	Ratio	unit	PNS-40(ψ8)	PNS-60(ψ14)	PNS-80(ψ19)	PNS-120(ψ24)	PNS-160(ψ35)			
1	3	Kg · cm ²	0.01	0.23	0.77	2.30	7.89			
	4		0.03	0.21	0.67	1.92	5.83			
	5~10		0.03	0.21	0.61	1.71	5.38			
Stage	Ratio		PNS-40(ψ8)	PNS-60(ψ14)/ PNS-60T(ψ8)	PNS-80(ψ19) / PNS-80T(ψ14)	PNS-120T(ψ19)	PNS-160(ψ35)/ PNS-160T(ψ24)			
2	15		0.04	0.23/(0.04)	0.77/(0.23)	0.77	5.38/(1.61)			
	Other ratios		0.03	0.21/(0.03)	0.61/(0.21)	0.61	5.38/(1.61)			
Stage	Ratio		PNS-40(ψ8)	PNS-60T(ψ8)	PNS-80T(ψ14)	PNS-120T(ψ19)	PNS-160T(ψ24)			
3	All ratios		0.03	0.03	0.21	0.61	1.61			
* 1. Applied to the output shaft center at 100 rpm.										
* 2. Measured at 3000 rpm with no load. These values are measured by gearbox with ratio = 10 (1-stage) or ratio = 100 (2-stage) at nominal input speed or 3000 rpm (if nominal input speed is higher than 3000 rpm) with no load.										
※ The above figures/specifications are subject to change without prior notice.										

Products due to human error, natural disasters or other factors lead to poor or damaged, will not be covered under warranty.

PLANETARY GEARHEADS



PHL PHFR PHF PGH PUR PUL PUA PGLH PGCH PGEH PGSH PGL PGC PGE SGC SGE PGRH PGR PGFR PGF PBC PBE PAE PAC PAN PGS PNS PGW